

Safety Limit Switches

Safety Limit Switches with rope

APPROVALS: UL 508 / CSA C22-2 N. 14

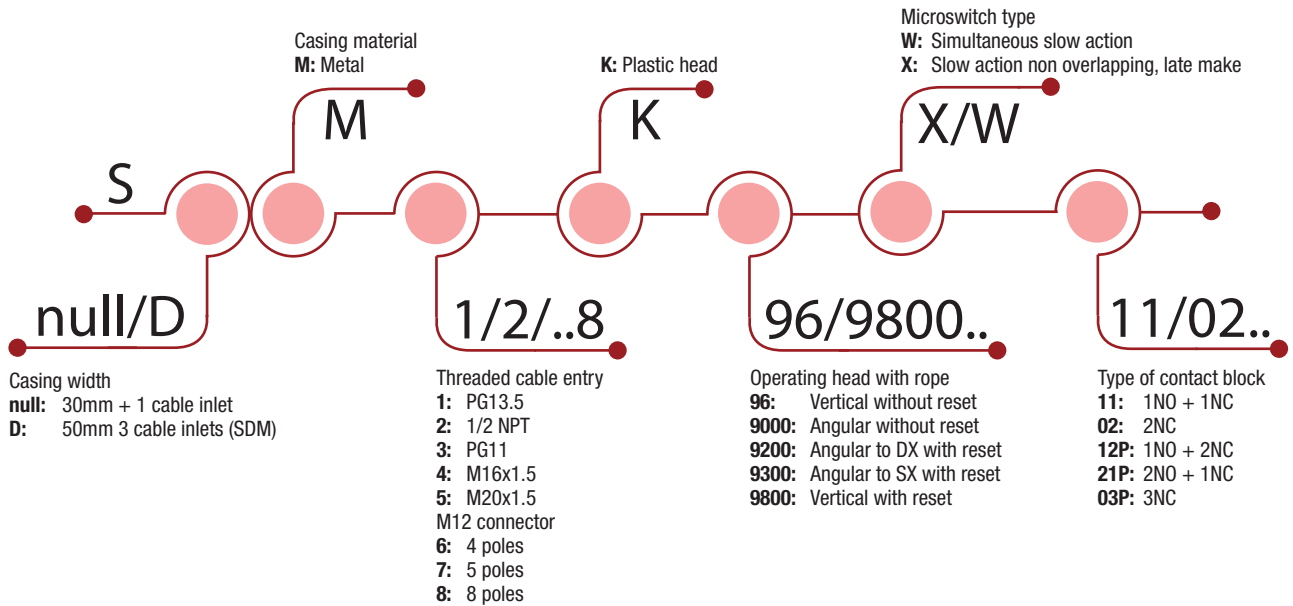

HOW IS IT MADE?

01 Casing

- SM with dimensions acc. to EN 50047

02 Mounting the casing

- 2 x M4 screws on top part for SM series
- 2 or 4 x M4 screws on top part for SDM series

03 Contact Block

- Positive opening operation
- Slow action contacts
- Contacts are electrically separated

04 Connecting terminals

- Block of 2 contacts: M3.5 (+, -) pozidriv 2 screws
- Block of 3 contacts: M3 (+, -) screws
- Screw head with captive cable clamp
- Markings conform with IEC 60947-1, IEC 60947-5-1 standard

05 Operating heads

- Straight
- 90° right
- 90° left

06 Reset

- Manual reset button for emergency stop

07 Cover

- 3 screws 3 pozidriv 1 for SM series
- 4 screws 3 pozidriv 1 for SDM series

08 Electrical connection

- 1 x threaded cable inlet suitable for cable gland (SM)
- 3 x threaded cable inlets suitable for cable gland (SDM)
- 1 x M12 connector for pre-wired solutions (SM)

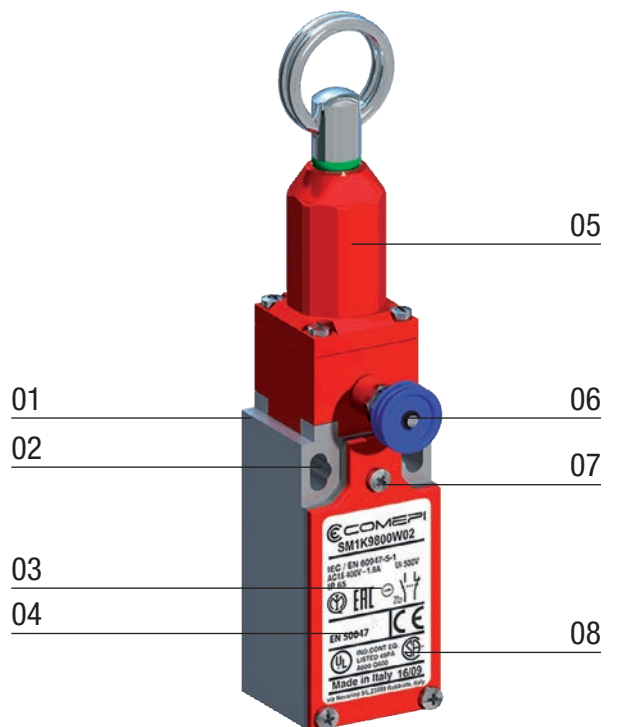

Safety Limit Switches

Safety Limit Switches with rope - Description

APPLICATIONS

Easy to use, the limit switches for safety applications with rope for simple and emergency stop offer specific qualities:

- Capability for strong current switching (conventional thermal current 10 A).
- Contact blocks with positive opening operation of the "N.C." normally closed contact(s) (symbol \ominus).
- Electrically separated contacts.
- Precision on operating positions (consistency).
- Immunity to electromagnetic disturbances.

The use of the Comepi pull wire safety switches allows you to create perimeter protections of the machines, thus reducing the need to install several emergency stop stations in different points of the machine. They comply with the requirements of European Directives (Low Voltage and Machines Directive) and are conform to European and international standards.

DESCRIPTION

SM/SDM series are made of zinc alloy (zamack). All metal limit switches have a degree of protection IP66.

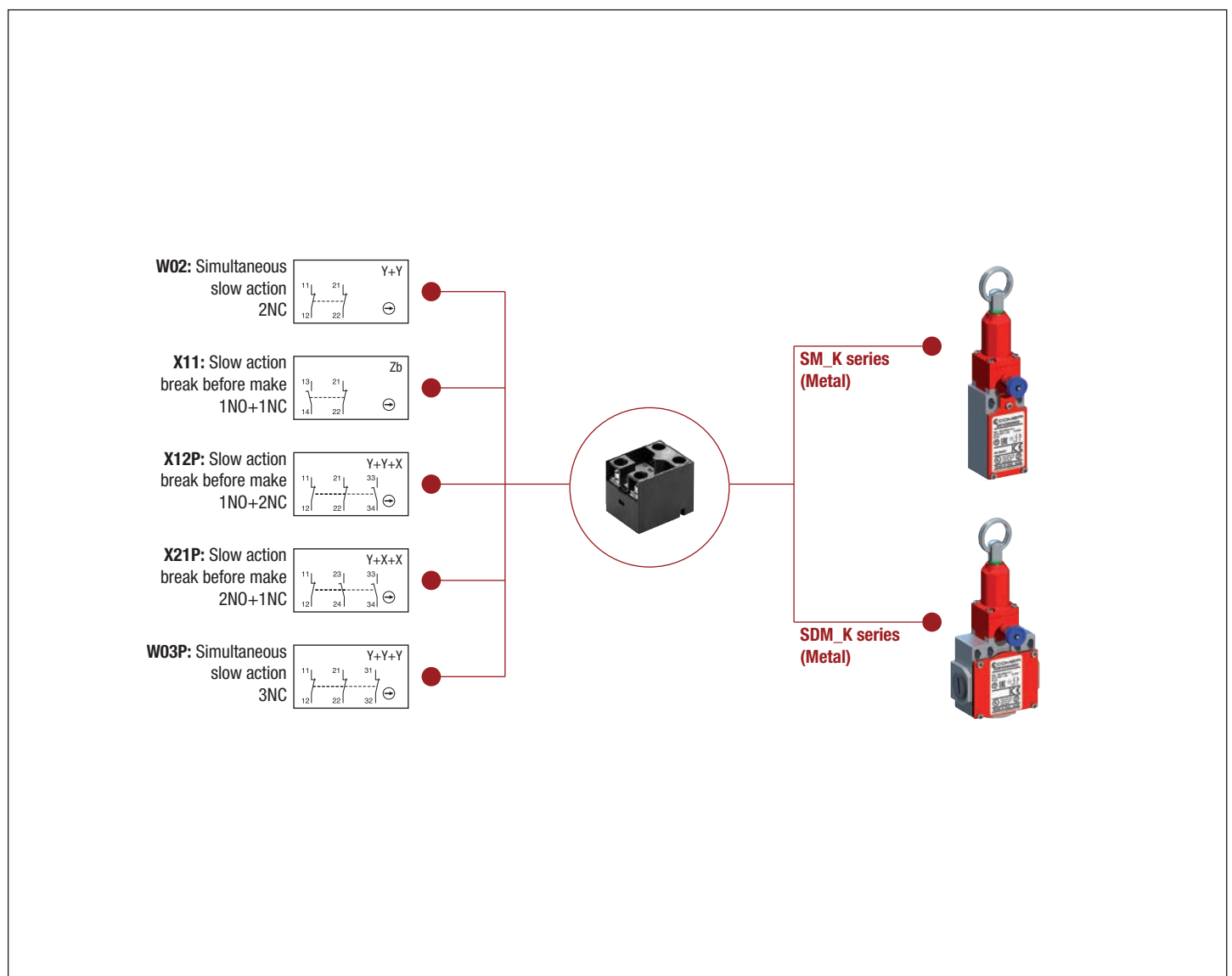

Safety Limit Switches

Safety Limit Switches with rope - Technical Data

	SM / SDM Series	
Standards	IEC 60947-5-1, EN 60947-5-1 EN 60947-5-5 (modelli con riarmo manuale)	
Certifications - Approvals	UL - CSA - IMQ - EAC - CCC	
Air temperature near the device		
– during operation	°C	– 25 ... + 70
– for storage	°C	– 30 ... + 80
Mounting positions	All positions are authorized	
Protection against electrical shocks (acc. to IEC 61140)	Class I	
Degree of protection (according to IEC 60529 and EN 60529)	IP 66	

Electrical Data

Rated insulation voltage U_i - according to IEC 60947-1 and EN 60947-1 - according to UL 508 and CSA C22-2 n° 14	500 V (degree of pollution 3) (400 V for contacts type X12P, X21P, W03P) A 600, Q 600 (A 300, Q 300 for SM/SDM series and contacts type X12P, X21P, W03P)	
Rated impulse withstand voltage U_{imp} (according to IEC 60947-1 and EN 60947-1)	kV	6
Conventional free air thermal current I_{th} (according to IEC 60947-5-1) $\theta < 40$ °C	A	10
Short-circuit protection $U_g < 500$ V a.c. - gG (gI) type fuses	A	10
Rated operational current I_e / AC-15 (according to IEC 60947-5-1)	24 V - 50/60 Hz A 120 V - 50/60 Hz A 400 V - 50/60 Hz A	10 6 4 (1.8A for contacts type X12, X21, W03)
I_e / DC-13 (according to IEC 60947-5-1)	24 V - d.c. A 125 V - d.c. A 250 V - d.c. A	6 (2.8A for contacts type X12, X21, W03) 0.55 0.4 (0.27A for contacts type X12, X21, W03)
Switching frequency	Cycles/h	3600
Load factor		0.5
Resistance between contacts	m Ω	25
Connecting terminals	M3.5 (+, -) pozidriv 2 screw with cable clamp (M3 for 3 poles contacts type)	
Terminal for protective conductor	M3.5 (+, -) pozidriv 2 screw with cable clamp	
Recommended tightening torque	Plastic	Metal
Cover	0,5Nm, max 0,8	0,8Nm, max 0,9
Head	0,5Nm, max 0,8	0,8Nm, max 0,9
Microswitch	0,8Nm, max 0,9	0,8Nm, max 0,9
Connecting capacity	1 or 2 x mm ²	0.34 ... 2.5 (0.34... 1.5 for 3 poles contacts type)
Terminal marking	According to IEC 60947-5-1	
Mechanical durability	500.000 operations	
Electrical durability (according to IEC 60947-5-1)	Utilization categories AC-15 and DC-13 (Load factor of 0.5 according to curves below)	
B10d	1 million of operations	

AC-15 - Snap action

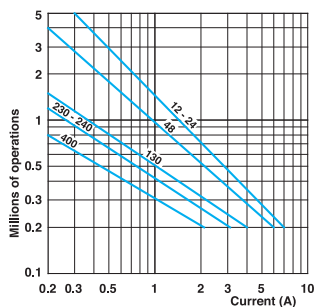

AC-15 - Slow action

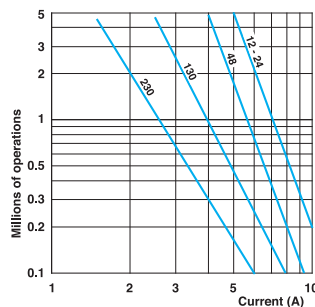

DC-13	Snap action	Slow action
	Power breaking for a durability of 5 million operating cycles	
Voltage 24 V	9.5 W	12 W
Voltage 48 V	6.8 W	9 W
Voltage 110 V	3.6 W	6 W

Safety Limit Switches

Safety Limit Switches with rope - Technical Data

Technical data approved by IMQ

Standards	Devices conform with international IEC 60947-5-1 and European EN 60947-5-1 standards	
Degree of protection	IP 66	
Rated insulation voltage U_i	500 V (degree of pollution 3) (400 V for contacts type X12P, X21P, W03P)	
Rated impulse withstand voltage U_{imp}	6 kV	
Conventional free air thermal current I_{th}	10 A	
Short-circuit protection - gG (gl) type fuses	10 A	
Rated operational current		
I_e / AC-15	24 V - 50/60 Hz	10 A
	400 V - 50/60 Hz	4 A (1.8A for contacts type X12, X21, W03)
I_e / DC-13	24 V - d.c.	6 A (2.8A for contacts type X12, X21, W03)
	125 V - d.c.	0,55 A
	250 V - d.c.	0.4 A (0.27A for contacts type X12, X21, W03)

Technical data approved by UL

Standards	Devices conform with UL 508
Contact blocks type X11, Y11, W02	A600, Q600
Utilization categories	(A300, Q300 when installed in SM/SDM series)
Contact blocks type X12, X21, W03	A600, Q600
Utilization categories	A600, Q600
Contact blocks type X12P, X21P and W03P	A300, Q300
Utilization categories	A300, Q300

Use 60/75°C copper (Cu) conductor only. Wire rages 14-18 AWG stranded or solid. The terminal tightening torque of 7 lbs-in / 0.78 Nm. Suitable for conduit connection only with use of adapter sleeve optionally provided or recommended by the manufacturer.

For the complete list of approved products, contact our technical department

IMPLEMENTATION

Operating head orientation

The head can be rotated each 90°.
Recommended tightening torque 0,5 Nm (max 0,8 Nm).

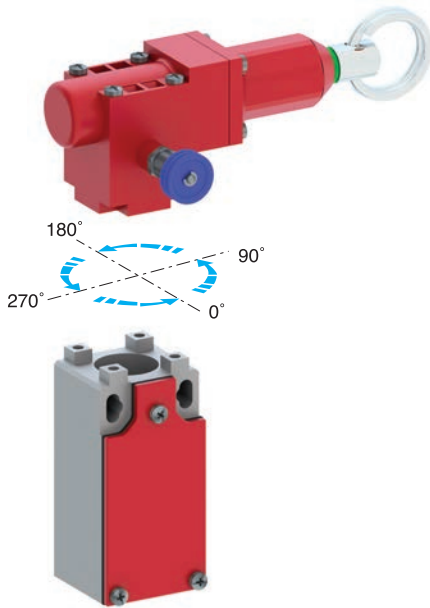

Examples of applications

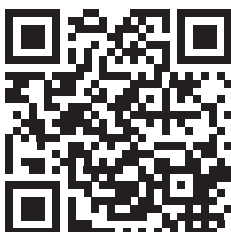
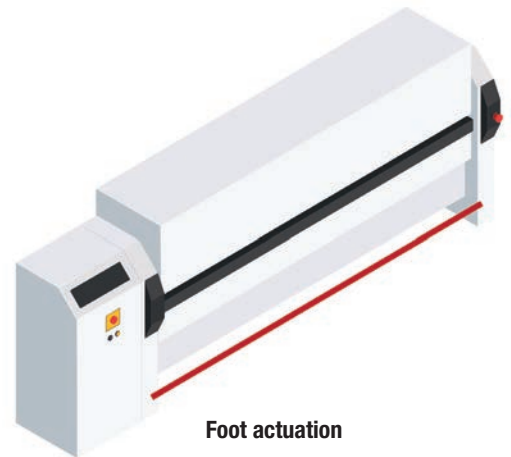
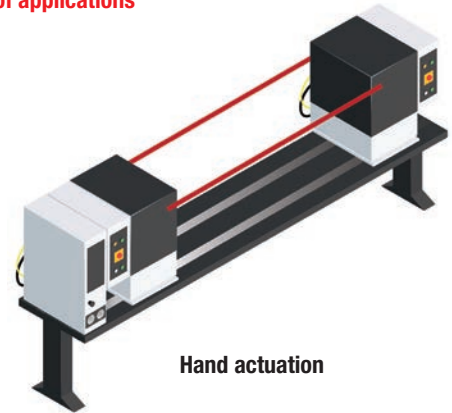

Download

Instruction sheet – Pull wire safety limit switches
CE declaration

Safety Limit Switches **SM/SDM_K**

Pull wire with reset for emergency stop - Metal casing - IP66

Electrical connection:

Replace the symbol "•" with the number of the thread desired

- 1: Cable gland PG 13.5
- 2: Cable gland 1/2" NPT (with adapter)
- 3: Cable gland PG 11
- 4: Cable gland M16 x 1,5
- 5: Cable gland M20 x 1,5
- 7: M12 5 poles connector
- 8: M12 8 poles connector

K9300 Pull wire with reset for emergency stop

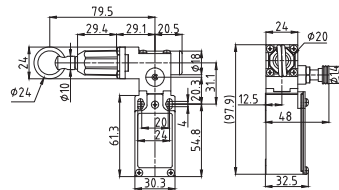

Min. forces Initial 65N, Final 85N (95N ⊖)
 Weight 275 g
 Operating diagram Page 117

K9800 Pull wire with reset for emergency stop

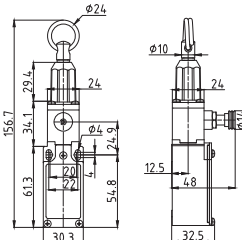

Min. forces Initial 60N, Final 80N (90N ⊖)
 Weight 230 g
 Operating diagram Page 117

K9200 Pull wire with reset for emergency stop

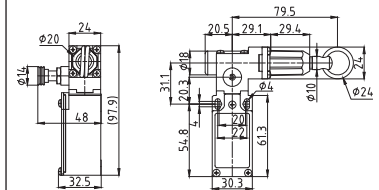

Min. forces Initial 65N, Final 85N (95N ⊖)
 Weight 275 g
 Operating diagram Page 117

Contact Blocks

X11 (1NO+1NC)	SM•K9300X11	SM•K9800X11	SM•K9200X11
W02 (2NC)	SM•K9300W02	SM•K9800W02	SM•K9200W02
X12P (1NO+2NC)	SM•K9300X12P	SM•K9800X12P	SM•K9200X12P
X21P (2NO+1NC)	SM•K9300X21P	SM•K9800X21P	SM•K9200X21P
W03P (3NC)	SM•K9300W03P	SM•K9800W03P	SM•K9200W03P

Electrical connection:

Replace the symbol "•" with the number of the thread desired

- 1: Cable gland PG 13.5
- 2: Cable gland 1/2" NPT (with adapter)
- 3: Cable gland PG 11
- 4: Cable gland M16 x 1,5
- 5: Cable gland M20 x 1,5

K9300 Pull wire with reset for emergency stop

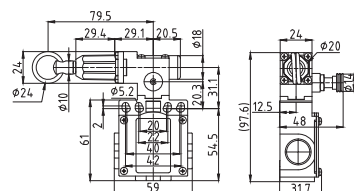

Min. forces Initial 65N, Final 85N (95N ⊖)
 Weight 365 g
 Operating diagram Page 117

K9800 Pull wire with reset for emergency stop

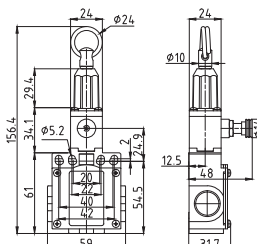

Min. forces Initial 60N, Final 80N (90N ⊖)
 Weight 320 g
 Operating diagram Page 117

K9200 Pull wire with reset for emergency stop

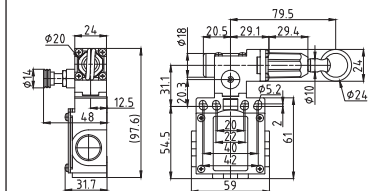

Min. forces Initial 65N, Final 85N (95N ⊖)
 Weight 365 g
 Operating diagram Page 117

Contact Blocks

X11 (1NO+1NC)	SDM•K9300X11	SDM•K9800X11	SDM•K9200X11
W02 (2NC)	SDM•K9300W02	SDM•K9800W02	SDM•K9200W02
X12P (1NO+2NC)	SDM•K9300X12P	SDM•K9800X12P	SDM•K9200X12P
X21P (2NO+1NC)	SDM•K9300X21P	SDM•K9800X21P	SDM•K9200X21P
W03P (3NC)	SDM•K9300W03P	SDM•K9800W03P	SDM•K9200W03P

Safety Limit Switches

Safety Limit Switches with rope

APPROVALS: UL 508 / CSA C22-2 N. 14

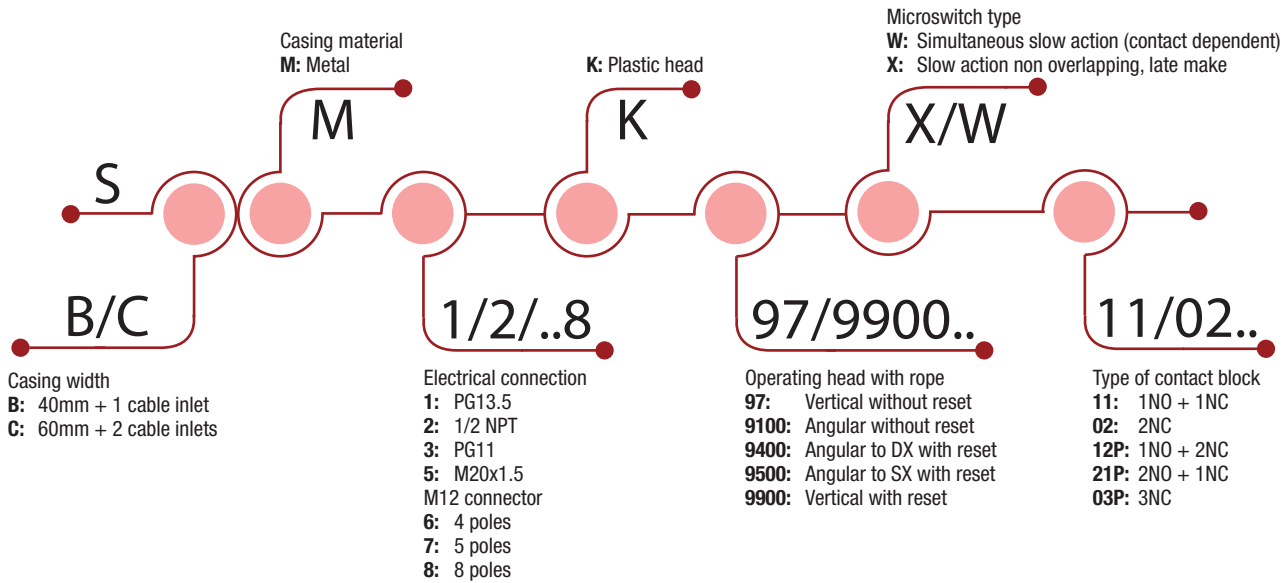

HOW IS IT MADE?

01 Casing

- SBM with dimensions acc. to EN 50041

02 Mounting the casing

- 2 x M5 screws on top part for SBM series
- 2 or 4 x M5 screws on top part for SCM series

03 Contact Block

- Positive opening operation
- Slow action contacts
- Contacts are electrically separated

04 Connecting terminals

- Block of 2 contacts: M3.5 (+, -) pozidriv 2 screws
- Block of 3 contacts: M3 (+, -) screws
- Screw head with captive cable clamp
- Markings conform with IEC 60947-1, IEC 60947-5-1 standard

05 Operating heads

- Straight
- 90° right
- 90° left

06 Reset

- Manual reset button for emergency stop

07 Cover

- 2 screws 3 pozidriv 1 for SBM series
- 4 screws 3 pozidriv 1 for SCM series

08 Electrical connection

- 1 x threaded cable inlet suitable for cable gland (SBM)
- 3 x threaded cable inlets suitable for cable gland (SCM)

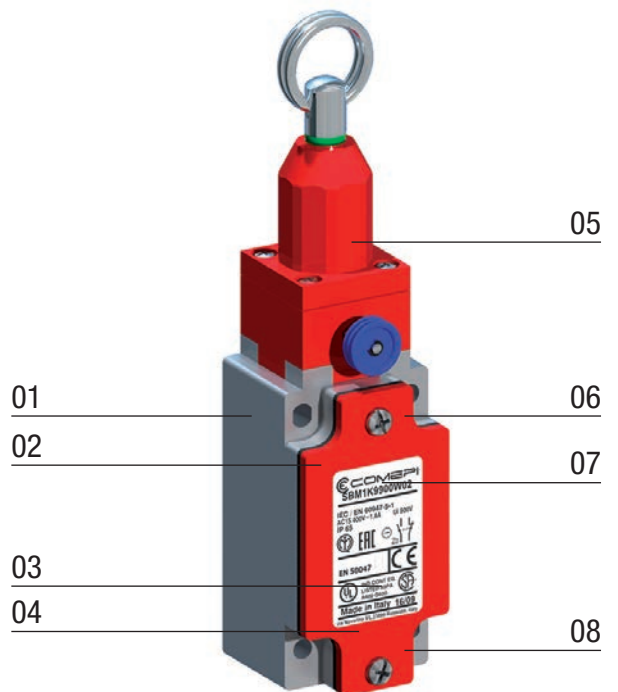

Safety Limit Switches

Safety Limit Switches with rope - Description

APPLICATIONS

Easy to use, the limit switches for safety applications with rope for simple and emergency stop offer specific qualities:

- Capability for strong current switching (conventional thermal current 10 A).
- Contact blocks with positive opening operation of the "N.C." normally closed contact(s) (symbol \ominus).
- Electrically separated contacts.
- Precision on operating positions (consistency).
- Immunity to electromagnetic disturbances.

The use of the Comepi pull wire safety switches allows you to create perimeter protections of the machines, thus reducing the need to install several emergency stop stations in different points of the machine. They comply with the requirements of European Directives (Low Voltage and Machines Directive) and are conform to European and international standards.

DESCRIPTION

SBM/SCM series are realized in aluminium material, therefore they are mechanically more resistant and three times lighter than the ones in zinc alloy. All metal limit switches have a degree of protection IP66.

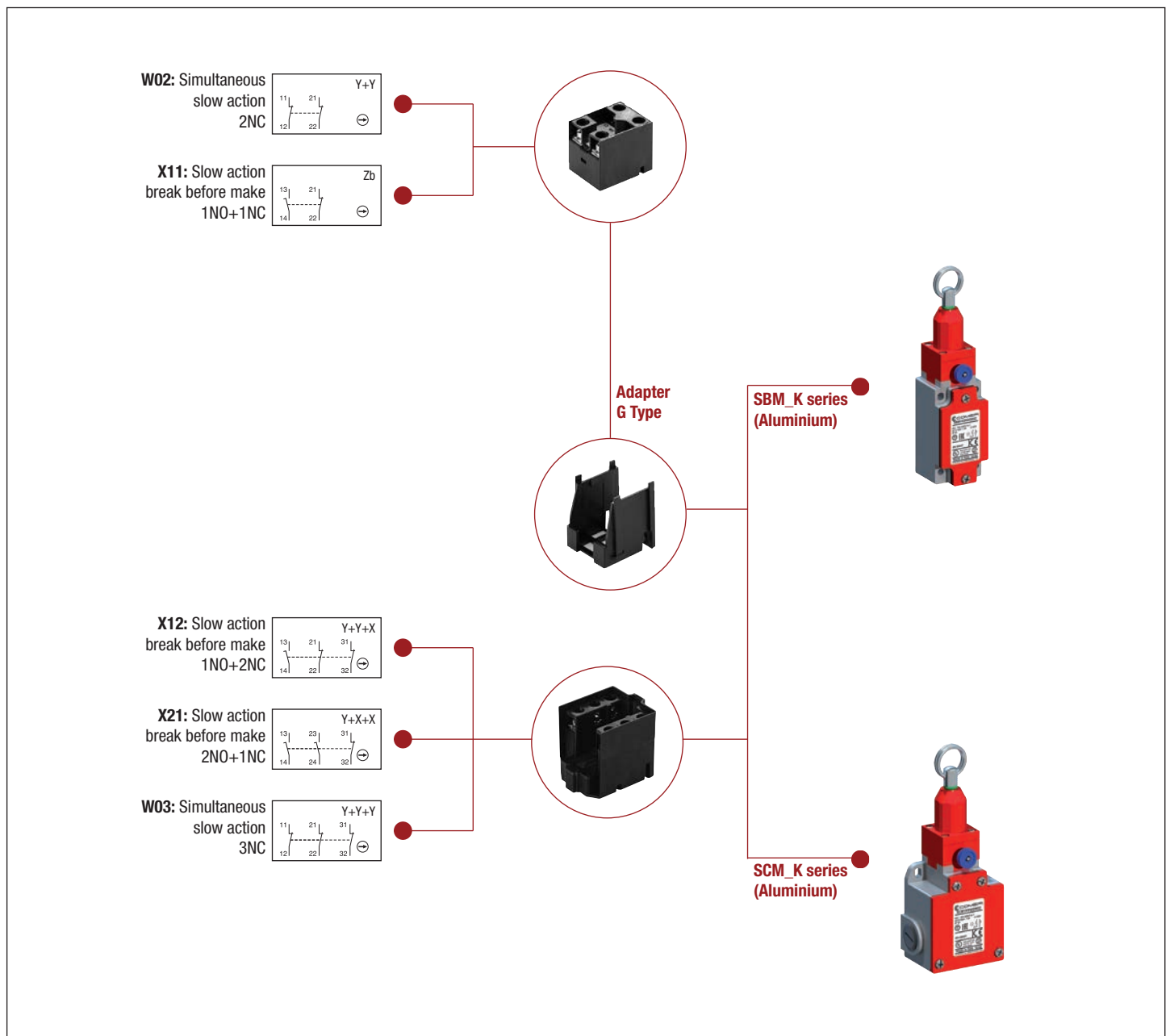

Safety Limit Switches

Safety Limit Switches with rope - Technical Data

	SBM / SCM Series	
Standards	IEC 60947-5-1, EN 60947-5-1 EN 60947-5-5 (modelli con riarmo manuale)	
Certifications - Approvals	UL - CSA - IMQ - EAC - CCC	
Air temperature near the device		
– during operation	°C	– 25 ... + 70
– for storage	°C	– 30 ... + 80
Mounting positions	All positions are authorized	
Protection against electrical shocks (acc. to IEC 61140)	Class I	
Degree of protection (according to IEC 60529 and EN 60529)	IP 66	

Electrical Data

Rated insulation voltage U_i - according to IEC 60947-1 and EN 60947-1 - according to UL 508 and CSA C22-2 n° 14	500 V (degree of pollution 3) (400 V for contacts type X12P, X21P, W03P) A 600, Q 600 (A 300, Q 300 for SM/SDM series and contacts type X12P, X21P, W03P)	
Rated impulse withstand voltage U_{imp} (according to IEC 60947-1 and EN 60947-1)	kV	6
Conventional free air thermal current I_{th} (according to IEC 60947-5-1) $\theta < 40$ °C	A	10
Short-circuit protection $U_g < 500$ V a.c. - gG (gI) type fuses	A	10
Rated operational current I_e / AC-15 (according to IEC 60947-5-1)	24 V - 50/60 Hz A 120 V - 50/60 Hz A 400 V - 50/60 Hz A	10 6 4 (1.8A for contacts type X12, X21, W03)
I_e / DC-13 (according to IEC 60947-5-1)	24 V - d.c. A 125 V - d.c. A 250 V - d.c. A	6 (2.8A for contacts type X12, X21, W03) 0.55 0.4 (0.27A for contacts type X12, X21, W03)
Switching frequency	Cycles/h	3600
Load factor		0.5
Resistance between contacts	m Ω	25
Connecting terminals	M3.5 (+, -) pozidriv 2 screw with cable clamp (M3 for 3 poles contacts type)	
Terminal for protective conductor	M3.5 (+, -) pozidriv 2 screw with cable clamp	
Recommended tightening torque	Plastic	Metal
Cover	0,5Nm, max 0,8	0,8Nm, max 0,9
Head	0,5Nm, max 0,8	0,8Nm, max 0,9
Microswitch	0,8Nm, max 0,9	0,8Nm, max 0,9
Connecting capacity	1 or 2 x mm ²	0.34 ... 2.5 (0.34... 1.5 for 3 poles contacts type)
Terminal marking	According to IEC 60947-5-1	
Mechanical durability	500.000 operations	
Electrical durability (according to IEC 60947-5-1)	Utilization categories AC-15 and DC-13 (Load factor of 0.5 according to curves below)	
B10d	1 million of operations	

AC-15 - Snap action

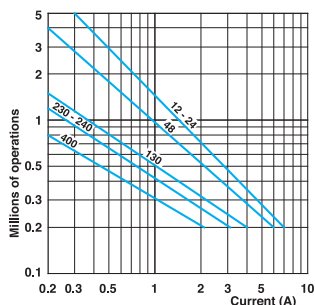

AC-15 - Slow action

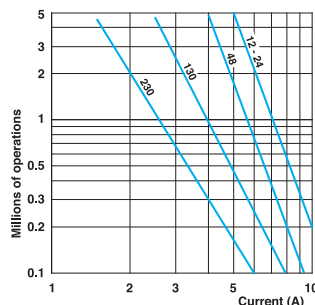

DC-13	Snap action	Slow action
	Power breaking for a durability of 5 million operating cycles	
Voltage 24 V	9.5 W	12 W
Voltage 48 V	6.8 W	9 W
Voltage 110 V	3.6 W	6 W

Safety Limit Switches

Safety Limit Switches with rope - Technical Data

Technical data approved by IMQ

Standards	Devices conform with international IEC 60947-5-1 and European EN 60947-5-1 standards	
Degree of protection	IP 66	
Rated insulation voltage U_i	500 V (degree of pollution 3) (400 V for contacts type X12P, X21P, W03P)	
Rated impulse withstand voltage U_{imp}	6 kV	
Conventional free air thermal current I_{th}	10 A	
Short-circuit protection - gG (gl) type fuses	10 A	
Rated operational current		
I_e / AC-15	24 V - 50/60 Hz	10 A
	400 V - 50/60 Hz	4 A (1.8A for contacts type X12, X21, W03)
I_e / DC-13	24 V - d.c.	6 A (2.8A for contacts type X12, X21, W03)
	125 V - d.c.	0,55 A
	250 V - d.c.	0.4 A (0.27A for contacts type X12, X21, W03)

Technical data approved by UL

Standards	Devices conform with UL 508
Contact blocks type X11, Y11, W02	A600, Q600
Utilization categories	(A300, Q300 when installed in SM/SDM series)
Contact blocks type X12, X21, W03	A600, Q600
Utilization categories	A600, Q600
Contact blocks type X12P, X21P and W03P	A300, Q300
Utilization categories	A300, Q300

Use 60/75°C copper (Cu) conductor only. Wire rages 14-18 AWG stranded or solid. The terminal tightening torque of 7 lbs-in / 0.78 Nm. Suitable for conduit connection only with use of adapter sleeve optionally provided or recommended by the manufacturer.

For the complete list of approved products, contact our technical department

IMPLEMENTATION

Operating head orientation

The head can be rotated each 90°.
Recommended tightening torque 0,5 Nm (max 0,8 Nm).

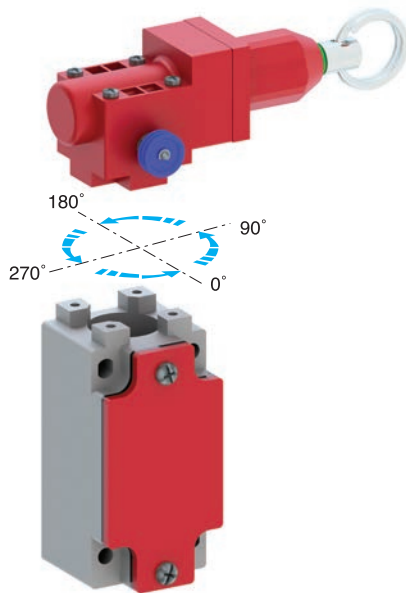

Examples of applications

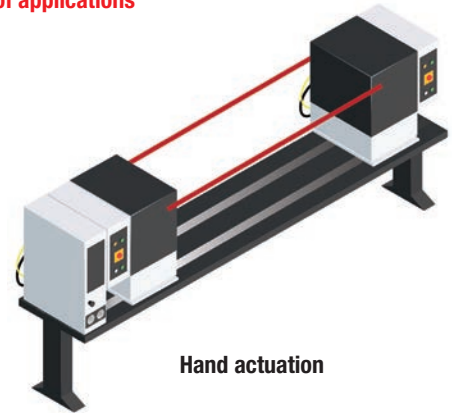

Hand actuation

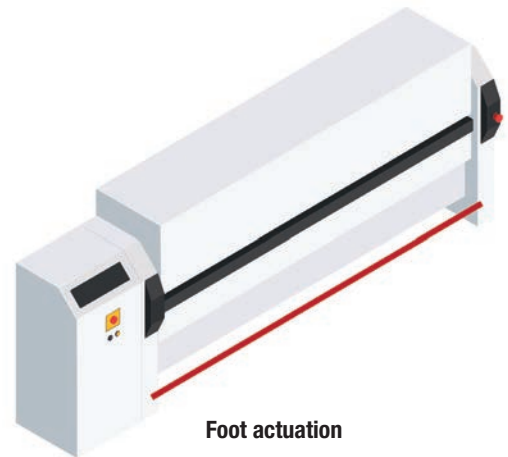

Foot actuation



Download

Instruction sheet – Pull wire safety limit switches
CE declaration

Safety Limit Switches **SBM/SCM_K**

Pull wire with reset for emergency stop - Metal casing - IP66

Electrical connection:

Replace the symbol “•” with the number of the thread desired

- 1: Cable gland PG 13.5
- 2: Cable gland 1/2" NPT
- 5: Cable gland M20 x 1,5

K9500 Pull wire with reset for emergency stop

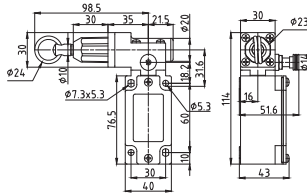

Min. forces Initial 150N, Final 215N (230N ⊖)
 Weight 320 g
 Operating diagram Page 117

K9900 Pull wire with reset for emergency stop

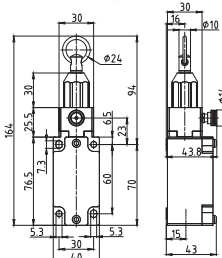

Min. forces Initial 120N, Final 160N (170N ⊖)
 Weight 250 g
 Operating diagram Page 117

K9400 Pull wire with reset for emergency stop

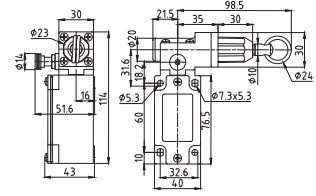

Min. forces Initial 150N, Final 215N (230N ⊖)
 Weight 320 g
 Operating diagram Page 117

Contact Blocks

X11 (1NO+1NC)	SBM•K9500X11	SBM•K9900X11	SBM•K9400X11
W02 (2NC)	SBM•K9500W02	SBM•K9900W02	SBM•K9400W02
X12 (1NO+2NC)	SBM•K9500X12	SBM•K9900X12	SBM•K9400X12
X21 (2NO+1NC)	SBM•K9500X21	SBM•K9900X21	SBM•K9400X21
W03 (3NC)	SBM•K9500W03	SBM•K9900W03	SBM•K9400W03

Electrical connection:

Replace the symbol “•” with the number of the thread desired

- 1: Cable gland PG 13.5
- 2: Cable gland 1/2" NPT
- 5: Cable gland M20 x 1,5

K9500 Pull wire with reset for emergency stop

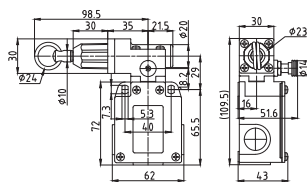

Min. forces Initial 150N, Final 215N (230N ⊖)
 Weight 345 g
 Operating diagram Page 117

K9900 Pull wire with reset for emergency stop

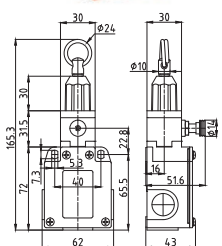

Min. forces Initial 120N, Final 160N (170N ⊖)
 Weight 275 g
 Operating diagram Page 117

K9400 Pull wire with reset for emergency stop

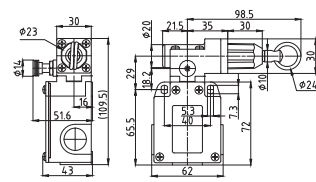

Min. forces Initial 150N, Final 215N (230N ⊖)
 Weight 345 g
 Operating diagram Page 117

Contact Blocks

X11 (1NO+1NC)	SCM•K9500X11	SCM•K9900X11	SCM•K9400X11
W02 (2NC)	SCM•K9500W02	SCM•K9900W02	SCM•K9400W02
X12 (1NO+2NC)	SCM•K9500X12	SCM•K9900X12	SCM•K9400X12
X21 (2NO+1NC)	SCM•K9500X21	SCM•K9900X21	SCM•K9400X21
W03 (3NC)	SCM•K9500W03	SCM•K9900W03	SCM•K9400W03

Safety Limit Switches **SBM/SCM_K**

Pull wire without reset for simple stop - Metal casing - IP66

Electrical connection:

Replace the symbol “•” with the number of the thread desired

- 1: Cable gland PG 13.5
- 2: Cable gland 1/2" NPT
- 5: Cable gland M20 x 1,5

K97 Pull wire without reset for simple stop

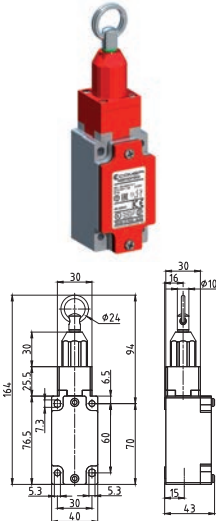

Min. forces Initial 120N, Final 160N (170N ☺)
 Weight 240 g
 Operating diagram Page 117

K9100 Pull wire without reset for simple stop

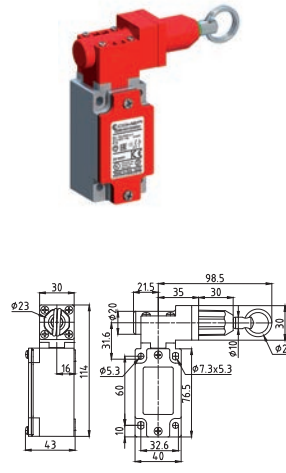

Min. forces Initial 150N, Final 215N (230N ☺)
 Weight 310 g
 Operating diagram Page 117

Contact Blocks

X11 (1NO+1NC)	SBM•K97X11	SBM•K9100X11
W02 (2NC)	SBM•K97W02	SBM•K9100W02
X12 (1NO+2NC)	SBM•K97X12	SBM•K9100X12
X21 (2NO+1NC)	SBM•K97X21	SBM•K9100X21
W03 (3NC)	SBM•K97W03	SBM•K9100W03

Electrical connection:

Replace the symbol “•” with the number of the thread desired

- 1: Cable gland PG 13.5
- 2: Cable gland 1/2" NPT
- 5: Cable gland M20 x 1,5

K97 Pull wire without reset for simple stop

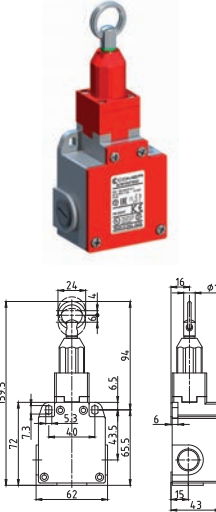

Min. forces Initial 120N, Final 160N (170N ☺)
 Weight 265 g
 Operating diagram Page 117

K9100 Pull wire without reset for simple stop

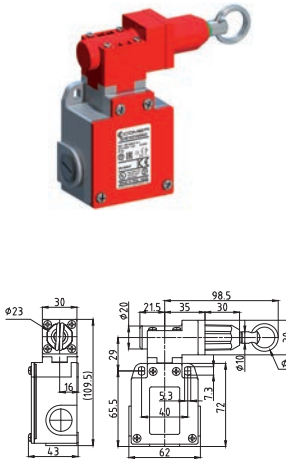

Min. forces Initial 150N, Final 215N (230N ☺)
 Weight 335 g
 Operating diagram Page 117

Contact Blocks

X11 (1NO+1NC)	SCM•K97X11	SCM•K9100X11
W02 (2NC)	SCM•K97W02	SCM•K9100W02
X12 (1NO+2NC)	SCM•K97X12	SCM•K9100X12
X21 (2NO+1NC)	SCM•K97X21	SCM•K9100X21
W03 (3NC)	SCM•K97W03	SCM•K9100W03

Safety Limit Switches

Safety Limit Switches with rope - Accessories

Stay Bolt

Code
OCC 08

Rope Clamp

Code
MOR 05

Rope eye

Code
RED 05

Rope ø 5mm

Code	Length
FUN05M010	10m
FUN05M015	15m
FUN05M020	20m
FUN05M025	25m
FUN05M102	102m

Code
SLS-FX1

Description
Hook stay bolt

Code
SLS-FX2

Description
Fixing clamp

Code
SLS-FX3

Description
Stay bolt

Code
SLS-M1

Description
Spring for SM, SDM series

Code
SLS-M2

Description
Spring for SBM, SCM series

Safety Limit Switches

Safety Limit Switches with rope

INSTALLATION INSTRUCTIONS

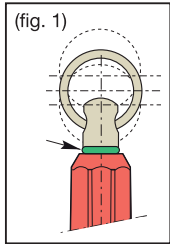

In order to obtain the correct operation of the device, please follow the following instructions.

1. Install the switch and secure the fixed end of the rope. Apply tension to the extent the green O-ring is visible and the bottom is flush with the end of the red housing. (Fig. 1).

2. Pull the reset pommel in order to close the safety contacts of the limit switch.
3. The contacts inside the limit switch will change their position whenever the rope is pulled or loose its tension.
4. Check the correct operation of the rope switch before you start the machine and periodically.

Performing the role of worker protection, improper installation or tampering with safety devices can cause serious injury to persons.

The installation must therefore be performed in accordance with local legislation and only by authorized personnel.

For any question about CE declaration of conformity or for any information and assistance, please contact our technical department

